



BELLA 4 MKII

4* Input 4 Sound Source Confidence Monitor



Highlights

- New 2019 Design
- Best In Class Loudspeakers
- 4 x 5 Watt Loudspeakers
- Dante® / AES67 Network Audio
- Peak, Presence & Mute Controls
- Low Noise Class D amplifier

Overview

This device uses Audinate's Ultimo Chipset, which can receive 4 incoming audio channels, each at 48kHz. However, this chipset can only receive these 4 audio channels from a maximum of 2 network locations (2 different devices). This is common with any manufacturer that uses this chipset.

The GlenSound Bella 4 is a 4 loudspeaker confidence monitoring rack. It features the very latest technology in loudspeaker and amplifier design giving it an extended acoustic frequency range (compared to old legacy equivalent products) and low distortion.

The 4 loudspeakers are each fed from their own* Dante® (AES67 compliant) network audio input. Each channel has a front panel audio presence indicator and input peak LED and an illuminated channel mute switch. Front panel volume controls adjust the audio output of the speakers and the headphone circuit.

Your operator will love the Bella 4 due to its great audio performance and simplicity of operation, your engineer will love it as it is well built and should last a very long time and your accountant will love it as it has low running costs and a very competitive initial asset price.

Features

Modern Loudspeaker Drive Units

The newly designed drive units fitted in the Bella 4 were originally manufactured as full range drive units in flat screen televisions. They have ultra modern Neodymium magnets with reasonably low tesla magnetic induction properties.

Class D Amplifiers

Each loudspeaker is driven from a new design of Class D amplifier. These amplifiers provide low distortion & low noise outputs. Four watts RMS is provided into each loudspeaker and the peak output is electronically limited to 5 watts.

**Inbuilt Loudspeaker Protection**

A compressor limiter circuit is provided to prevent overload and damage to the loudspeaker drivers by exceptionally high audio levels. One compressor/ limiter is provided for each loudspeaker and they have been carefully designed not to taint the audio during normal operating levels.

Dante®/ AES67 Compliant Audio Inputs

4* network audio inputs can be routed from your Dante®/ AES67 AoIP network to the Bella 4. The Bella 4 uses the Ultimo chipset from Audinate and can accept 4 audio inputs at 48k sampling or 2 at 96k sampling, all with up to 24 bit resolution.

Channel Mute Switch

Each channel has its own illuminated mute switch. This allows a quick and easy way for an operator to turn the audio off from one (or more) loudspeakers.

Presence & Peak LEDs

Presence LEDs are provided for each loudspeaker input. These LEDs illuminate when incoming audio is detected and this provides a helpful aid to an operator to know which audio circuit is currently active.

Peak LEDs are also provided and these illuminate when the input level reaches a high level.

Features

Headphone Output

A front panel 6.35mm TRS headphone jack is provided. If headphones are plugged in then the audio to the loudspeakers is automatically cut. The headphone output is stereo and is wired such that inputs 1 and 3 feed its left output and 2 and 4 feed the right output channel.

Mains Power Supply

An internal switch mode mains power supply is fitted that is suitable for use Worldwide. The power input is via an industry standard filtered IEC plug.

**High Acoustical Output**

The modern loudspeaker drive units are capable of providing a high output SPL of 88dB from 1 loudspeaker (at 0.6 metres) or 98dB if all loudspeakers are driven coherently.

Best in Class Frequency Response

Our design provides what we believe is the best in class frequency response from a 4 way 1RU loudspeaker rack. Our acoustical output is within +/-9dB from 22kHz down to 120Hz. The flat midrange and extended LF provide a noticeable improvement in audio clarity and we'd welcome any listening test comparison you wish to try.

The graph below plots acoustical output level in relation to frequency.

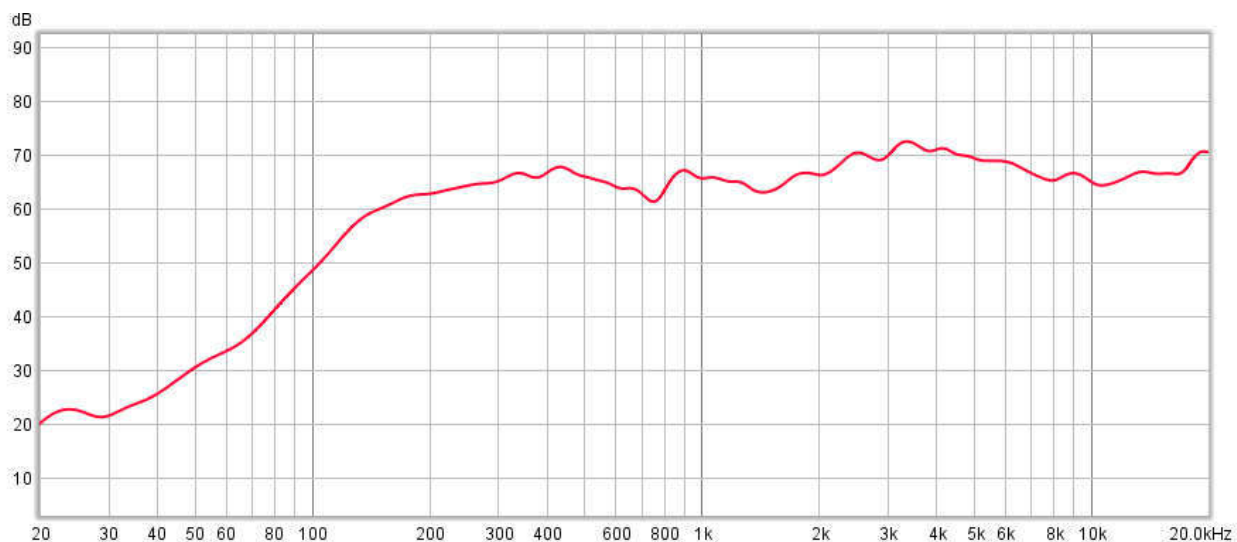

Audio Block Diagram

In England there is a common phrase 'Listen To Your Mother' which as a child often means that you're in trouble!

Dante Alighieri's mother was Bella Abati.

We therefore hope that if you listen to our Bella it will keep you out of trouble.

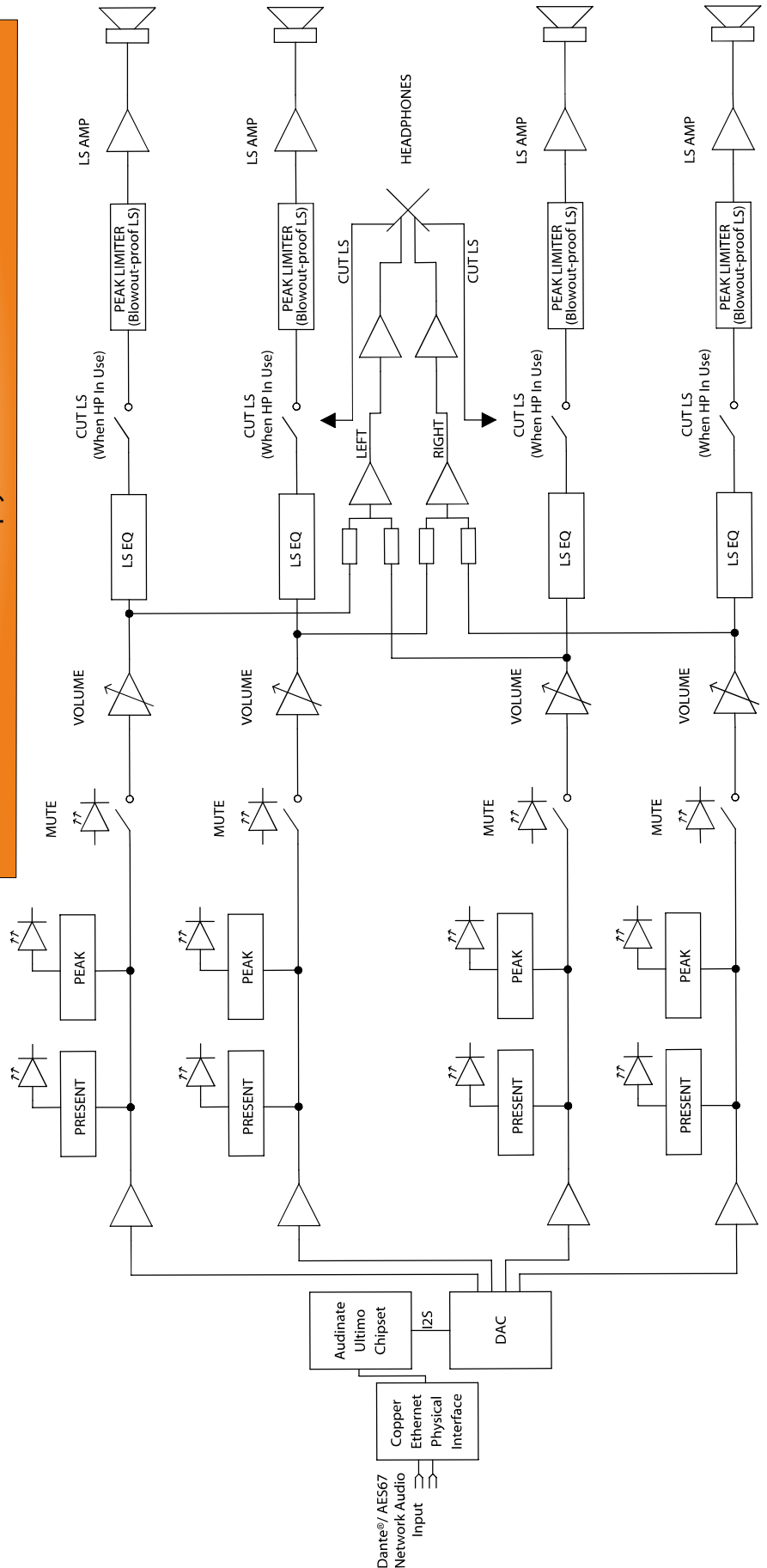

Dante® / AES67 Audio Monitor

NETWORK

Physical Interface

1 off RJ45 Neutrik Ethercon

Audio Sample Frequency

48kS/s

Transfer Rate

100 Mbps

Dante™ Chipset

Ultimo UXT-01-004

Note: Audinate recommend no more than 10 Ultimo chipsets on one network **UNLESS** another Dante™ device such as the Brooklyn Module (found in 8 channel Beatrice/ Dark units), is on the same network

AES67 Compliant

The Audinate Ultimo chipset is AES67 compliant

AUDIO - General

Volume Control Gain Range

+10/ Off

Present Indicator Threshold

-18dB

Present Indicator Hold Time

3 seconds

Peak LED Threshold

+10dB

AUDIO - Loudspeaker

Maximum Power RMS

4 Watts (per loudspeaker)

Peak Power (per loudspeaker)

5 Watts (limited by compressor circuit)

Amplifier Type

Class D

Noise @ Lineup (measured at I/P to LS)

> -61.5dB

THD + N (measured at input to LS)

> 0.18% @ 1kHz ref +8dB

Acoustic Frequency Response

120Hz to 22kHz +/- 9dB

Maximum Acoustic Level (1 Loudspeaker)

88dB SPL @ 0.61 Meters (2 Feet)

Maximum Acoustic Level (4 Loudspeakers)

98dB SPL @ 0.61 Meters (2 feet)

Loudspeaker Magnet Type

Neodymium

Magnetic Induction

1.15 T (per loudspeaker)

* FOUR INCOMING AUDIO CIRCUITS

This device uses Audinate's Ultimo Chipset. This chipset can receive 4 incoming audio channels each at 48kHz. However this chipset can only receive these 4 audio channels from a maximum of 2 network locations.

AUDIO - Headphones

Connector

6.35mm (1/4") TRS Jack Socket

Maximum Output Before Clipping

+18dB into 600 Ohms

Noise @ Lineup (22hz to 22kHz RMS)

> -88 dB

THD + N

> 0.0025% @1kHz ref +8dB

Headphone Impedance

32 - 1000 Ohms

POWER

Input Voltage

100 - 240 VAC +/-10%

Frequency

50 / 60 Hz

Input Connector

Filtered IEC (Internally fused)

Consumption

25 Watts (Maximum)

PHYSICAL

Mechanics

All aluminium with laser etched panels and light textured black powder coated lid/ base

Size

19" 1RU 164mm deep

Weight

1.35Kg (4.2lbs)

Shipping Weight

3.1Kg (6.8lbs)

Shipping Size

62 x 41 x12 cms

Shipping Carton

Rugged export quality cardboard

ENVIRONMENTAL

Operating Temperature

0 to +50 °C (32 to 122 °F)

Storage Temperature

-20 to +70 °C (-4 to 158 °F)

Relative Humidity

0 to 95% non-condensing

INCLUDED ITEMS

Handbook

By download

Mains Cable

2 metre IEC (UK & Europe only)

Network Cable

2 metre RJ45 to RJ45

E&OE